



# Installation Instructions HighRock 4x4™ Element Rear Doors

Vehicle Application:  
Jeep® Wrangler JL 4-Door 2018 and up  
Part Number 51741-01

## Installation Tips

Before you install your new High Rock 4x4™ Element Doors, please read all the instructions thoroughly.

**! WARNING** This product is designed primarily to enhance the appearance of the vehicle and to shield the occupants from ordinary weather conditions. Do not rely in any way on the components of this product to protect against injury or death in the event of an accident. Never operate the vehicle in excess of manufacturer’s specifications.

Read and follow, precisely, all installation instructions provided when installing this product. Failure to do so may result in a poor fit and could place occupants of the vehicle in a potentially dangerous situation.

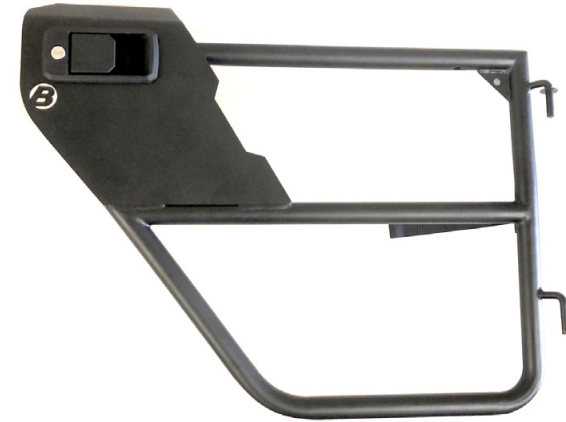

## WEAR SEAT BELTS AT ALL TIMES

Tools			Installation Time	Support
 Safety Glasses	 Ratchet	 T40 - T45 - T50 Torx Drivers	 30 Minutes	We're here to help! Go to <a href="http://www.Bestop.com">www.Bestop.com</a> and click on "Contact Us"
 T20 - T30 Torx Drivers	 10mm Wrench	 4mm - 5mm Allen Wrenches	<b>Skill Level</b>  1 - Easy	



## Installation Instructions HighRock 4x4™ Element Rear Doors

Vehicle Application:  
Jeep® Wrangler JL 4-Door 2018 and up  
Part Number 51741-01

### Sugerencias de Instalación

**Antes de empezar a instalar esta unidad, lea atentamente todas las instrucciones.**

#### Para un buen ajuste:

Para facilitar la instalación, el producto debe instalarse a temperaturas superiores a 72 °F (22 °C).

Por debajo de esta temperatura, la tela puede encogerse una pulgada o más, lo que dificultaría su ajuste al vehículo.

Es normal que la tela se contraiga o arrugue cuando está guardada en la caja de empaque. A los pocos días después de la instalación, la tela se relajará y las arrugas desaparecerán.



#### ADVERTENCIA

Este producto se diseñó principalmente para mejorar la apariencia del vehículo y proteger a los ocupantes de las condiciones climáticas comunes. De ninguna manera piense que los componentes de este producto pueden servir como medio de contención para los ocupantes del vehículo o que pueden protegerlos contra lesiones o la muerte en caso de accidente. Este producto no protegerá a los ocupantes contra caídas de objetos. Nunca conduzca este vehículo fuera de las especificaciones del fabricante.

#### USE LOS CINTURONES DE SEGURIDAD EN TODO MOMENTO

Lea y siga con precisión todas las instrucciones de instalación que se proporcionan para instalar este producto. Si no lo hace, podría producirse un mal ajuste que colocaría a los ocupantes del vehículo en una situación potencialmente peligrosa.



#### PRECAUCIÓN

Debe usar gafas protectoras en todo momento durante la instalación de este producto.

### Conseils pour l'installation

**Lire toutes les instructions au complet avant de commencer l'installation de cet assemblage.**

#### Pour un ajustement sans problème :

Afin de faciliter l'installation, ce produit doit être installé à des températures au-dessus de 72 °F (22 °C).

Sous cette température, le tissu peut rétrécir d'un pouce (2,5 cm) ou plus, ce qui rendra l'ajustement sur le véhicule difficile.

Il est normal que le tissu rétrécisse et plisse pendant qu'il est dans la boîte d'expédition. En quelques jours après l'installation, le tissu se détendra et les plis disparaîtront.



#### AVERTISSEMENT

Ce produit est conçu principalement pour améliorer l'apparence du véhicule et pour protéger les occupants des conditions météorologiques usuelles. Ne jamais se fier aux composants de ce produit pour se protéger de blessures ou de la mort en cas d'accident. Ce produit ne protégera pas les occupants des chutes d'objets. Ne jamais utiliser le véhicule au-delà des caractéristiques techniques indiquées par le fabricant.

#### PORTER UNE CEINTURE DE SÉCURITÉ EN TOUT TEMPS

Lire et suivre, très fidèlement, toutes les instructions d'installation fournies lors de l'installation de ce produit. Ne pas suivre cette consigne peut causer une installation inadéquate et mettre les occupants du véhicule dans une situation potentiellement dangereuse.



#### MISE EN GARDE

Des lunettes de sécurité doivent être portées en tout temps lors de l'installation de ce produit.







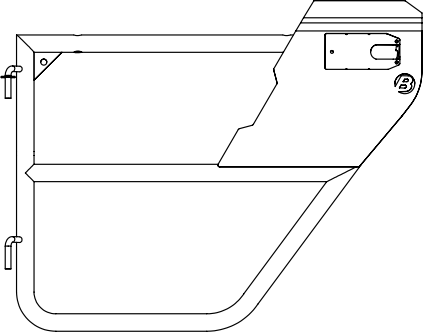
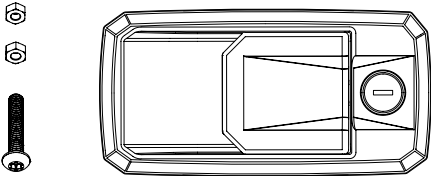
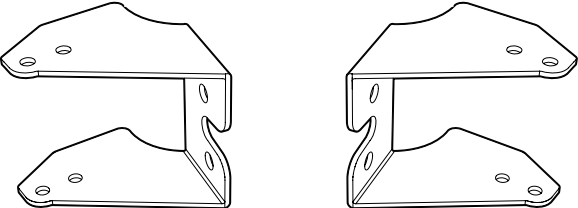
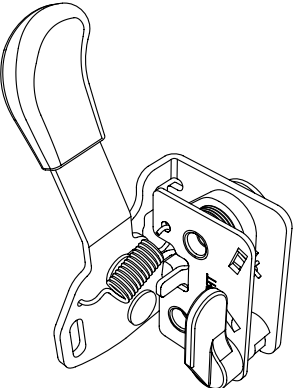
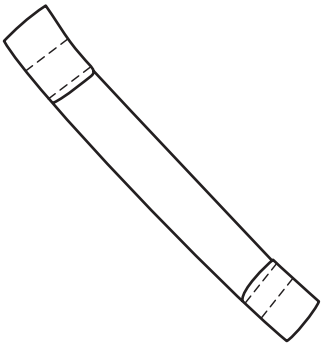
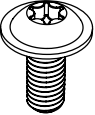
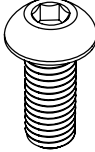
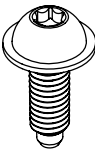
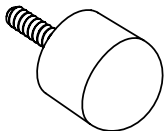
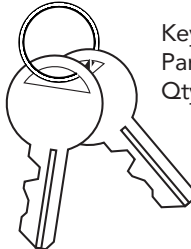

# Installation Instructions HighRock 4x4™ Element Rear Doors

Vehicle Application:  
Jeep® Wrangler JL 4-Door 2018 and up  
Part Number 51741-01

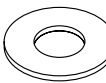
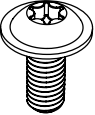
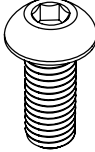
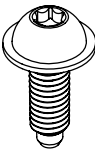
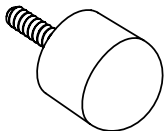
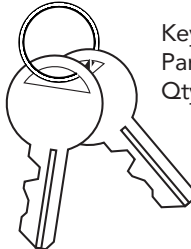
## Parts List

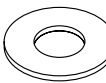
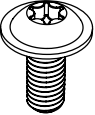
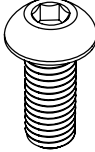
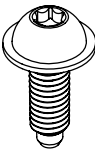
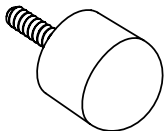
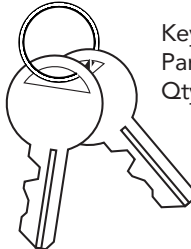
- Required parts for installation - Page number in Installation Guide

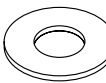
All Sections	Element™ Door Parts		Multiple Pages																		
 <p>Door Frames Left (shown) Part #584.35 (matte finish) Right #584.34 (matte finish) Qty. 1 of each</p>	 <p>Locking Paddle Latch with Adjustment Screw and Jam Nuts (2) Part #584.61 Qty. 2</p>		 <p>Rotor Brackets Part #548.33 - Left Part #548.34 - Right Qty. 1 of each</p>																		
 <p>Rotor Assembly Part #584.45 - Left Part #584.44 - Right (shown) Qty. 1 of each</p>	 <p>Door Restraint Part #428.59 Qty. 2</p>	<p><b>Small Parts Kit #577.71</b></p> <table border="0"> <tr> <td data-bbox="884 1019 978 1133">  </td> <td data-bbox="989 1027 1199 1141"> <p>M5x0.8x12 Button Head Screw Part #531.49 Qty. 6</p> </td> <td data-bbox="1262 1019 1356 1170">  </td> <td data-bbox="1367 1027 1577 1141"> <p>M8x1.25x20 Button Head Screw Part #431.59 Qty. 4</p> </td> <td data-bbox="1640 1019 1734 1170">  </td> <td data-bbox="1755 1027 1986 1170"> <p>M6x1.0x15 Flanged Button Head Screw Part #533.61 Qty. 8</p> </td> </tr> <tr> <td data-bbox="915 1219 1079 1349">  </td> <td data-bbox="915 1365 1058 1455"> <p>Bumper Part #585.04 Qty. 2</p> </td> <td data-bbox="1171 1227 1360 1474">  </td> <td data-bbox="1325 1243 1465 1333"> <p>Key Part #564.19 Qty. 2</p> </td> <td data-bbox="1640 1219 1734 1317">  </td> <td data-bbox="1755 1219 1898 1333"> <p>M6x1.0 Flanged Nut Part #515.82 Qty. 8</p> </td> </tr> <tr> <td data-bbox="1629 1382 1734 1463">  </td> <td data-bbox="1755 1382 1927 1471"> <p>M8 Flat Washer Part #515.84 Qty. 4</p> </td> <td colspan="3"></td> </tr> </table>				<p>M5x0.8x12 Button Head Screw Part #531.49 Qty. 6</p>		<p>M8x1.25x20 Button Head Screw Part #431.59 Qty. 4</p>		<p>M6x1.0x15 Flanged Button Head Screw Part #533.61 Qty. 8</p>		<p>Bumper Part #585.04 Qty. 2</p>		<p>Key Part #564.19 Qty. 2</p>		<p>M6x1.0 Flanged Nut Part #515.82 Qty. 8</p>		<p>M8 Flat Washer Part #515.84 Qty. 4</p>			
	<p>M5x0.8x12 Button Head Screw Part #531.49 Qty. 6</p>		<p>M8x1.25x20 Button Head Screw Part #431.59 Qty. 4</p>		<p>M6x1.0x15 Flanged Button Head Screw Part #533.61 Qty. 8</p>																
	<p>Bumper Part #585.04 Qty. 2</p>		<p>Key Part #564.19 Qty. 2</p>		<p>M6x1.0 Flanged Nut Part #515.82 Qty. 8</p>																
	<p>M8 Flat Washer Part #515.84 Qty. 4</p>																				

**Step 1**

**Tools**



Ratchet



T50  
Torx Driver

**Step 2**

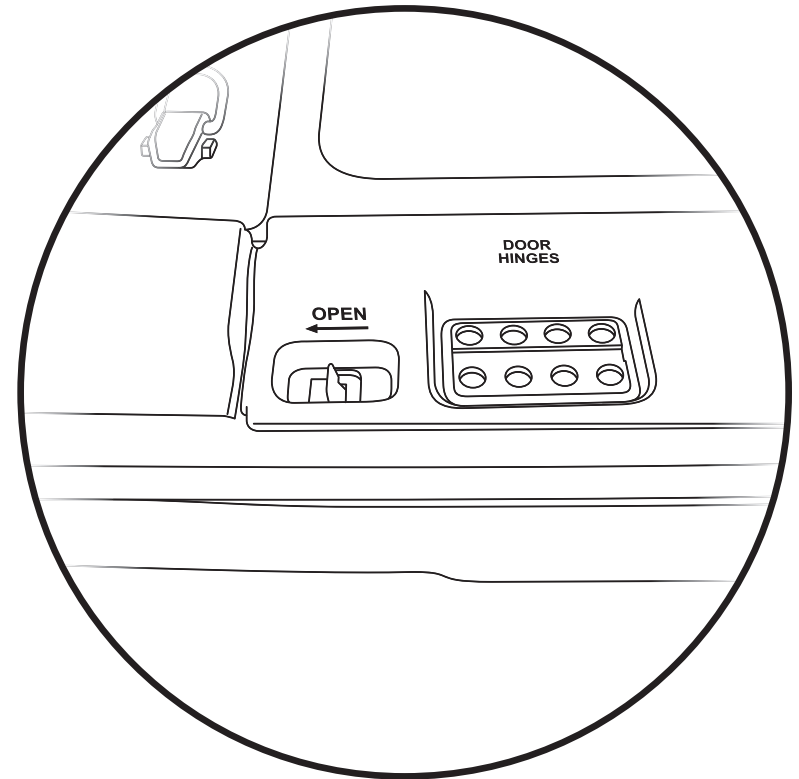
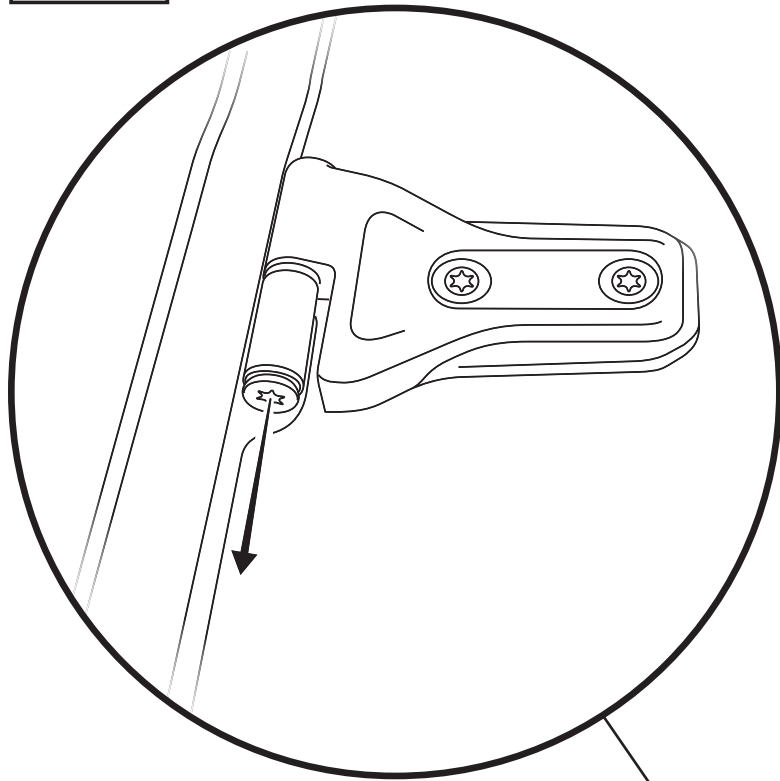

**Step 1**

Using a T50 Torx bit, remove the Hinge Screws from the bottom of each door hinge - 2-door or 4-door.

**Step 2**

Store the Door Hinge Screws underneath the hinged floor cover at the rear of the Jeep.

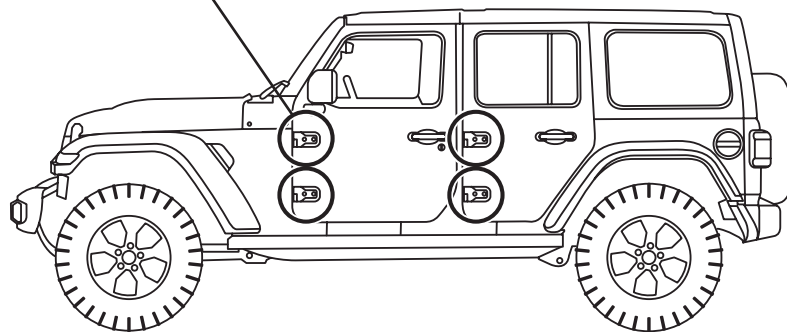

**Step 1**

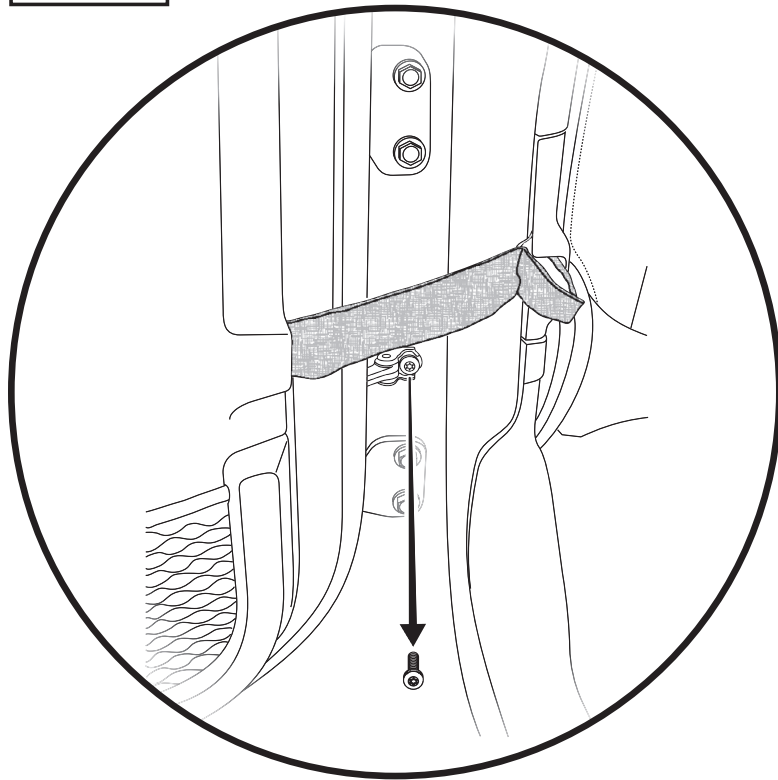

**Tools**



Ratchet



T40  
Torx Driver

**Step 2**

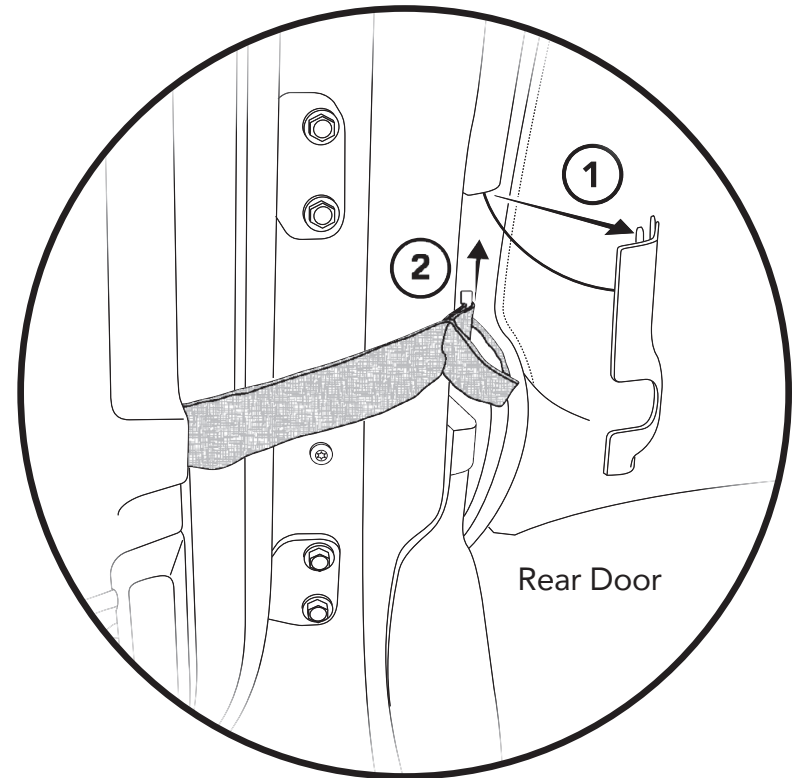

**Step 1**

Using a T40 Torx bit, remove the door linkage screw on the inside of the door frame.

Move the door linkage aside and replace the screw.

Do this on each door that you are removing, on both 2 and 4-door Jeeps.

**Step 2**

Rear Door:

- ① Remove the tethered plastic cover over the Door Retention Strap Hook.
- ② Remove the loop end of the Door Retention Strap from the Hook. Lift the loop up and off of the metal hook.

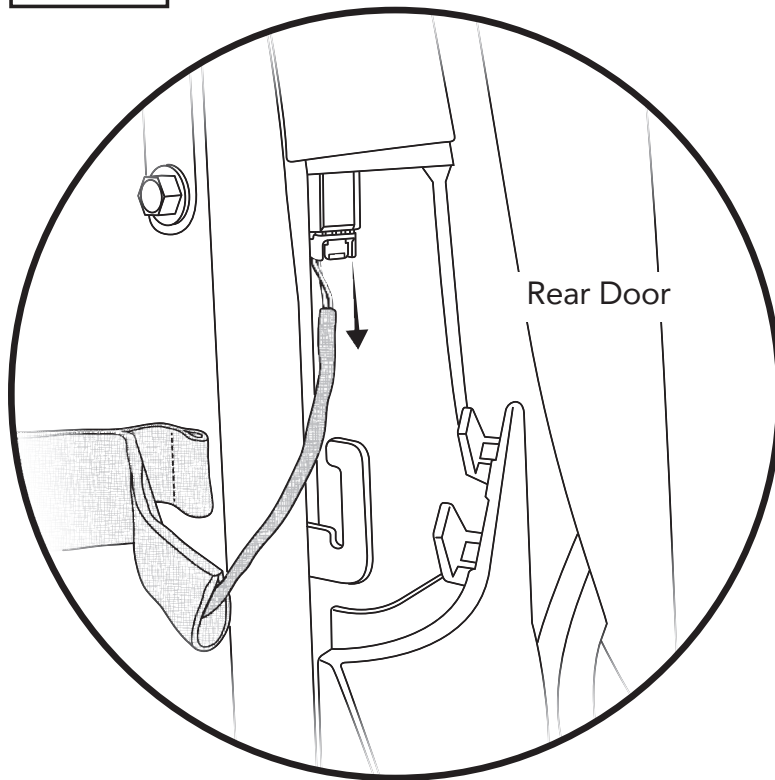
**Step 1****Step 1**

Rear Door:

With the tethered plastic cover removed, unplug the connector behind the cover, and at the end of the wrapped wire bundle that is inside of the door restraint strap.

Replace the plastic cover after you have unplugged the connector.

You may now lift this door off the hinge.

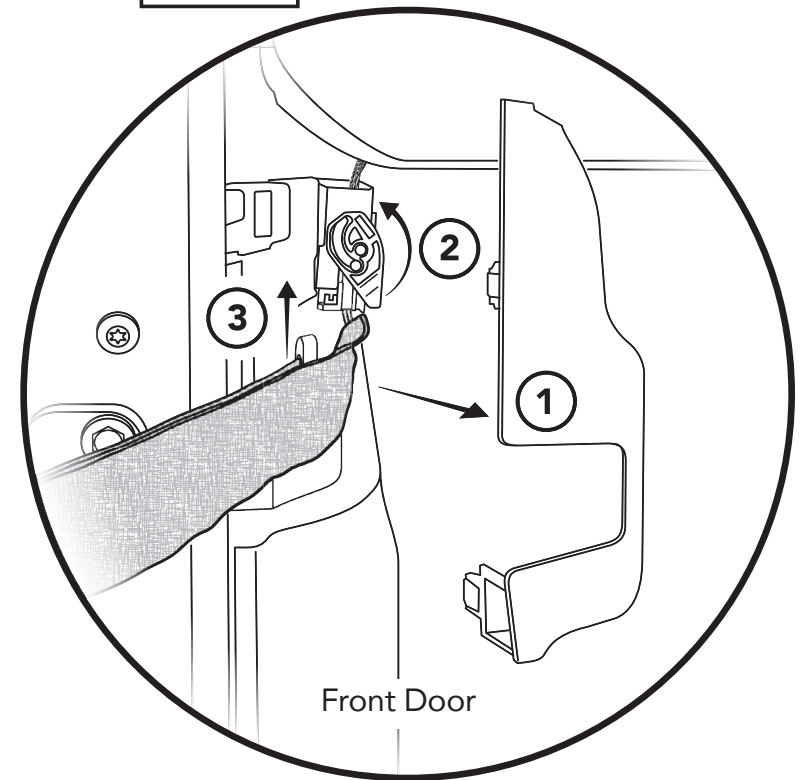
**Step 2****Step 2**

Front Door:

① Remove the tethered plastic cover over the Door Retention Strap Hook.

② Slide the red latch on the connector up, and pivot the white receptacle lock 180°, and remove the connector.

③ Remove the loop end of the Door Retention Strap from the Hook. Lift the loop up and off of the metal hook.

You may now lift this door off the hinge.

Step 1 584.61

Hardware

Tools

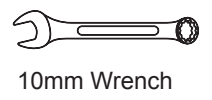
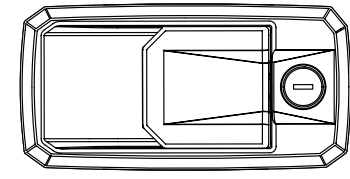

Locking Paddle Latch with Adjustment Screw and Jam Nuts (2)  
Part #584.61  
Qty. 2

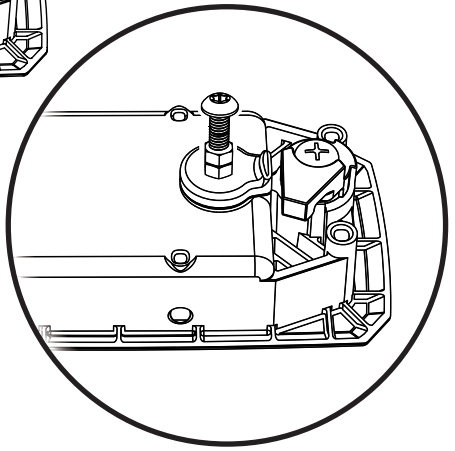
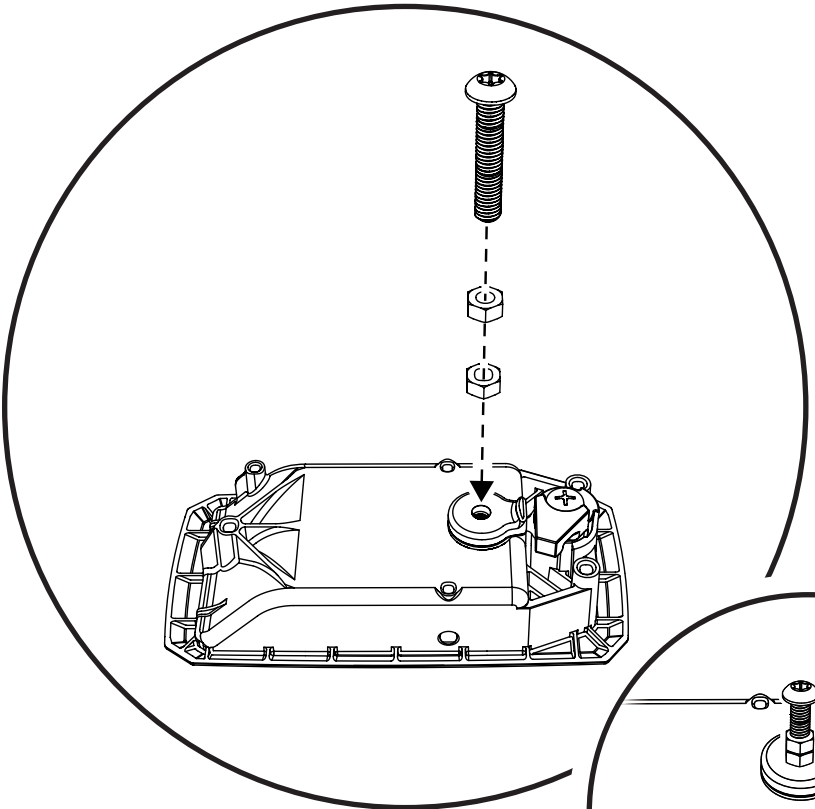

See caution on page 10

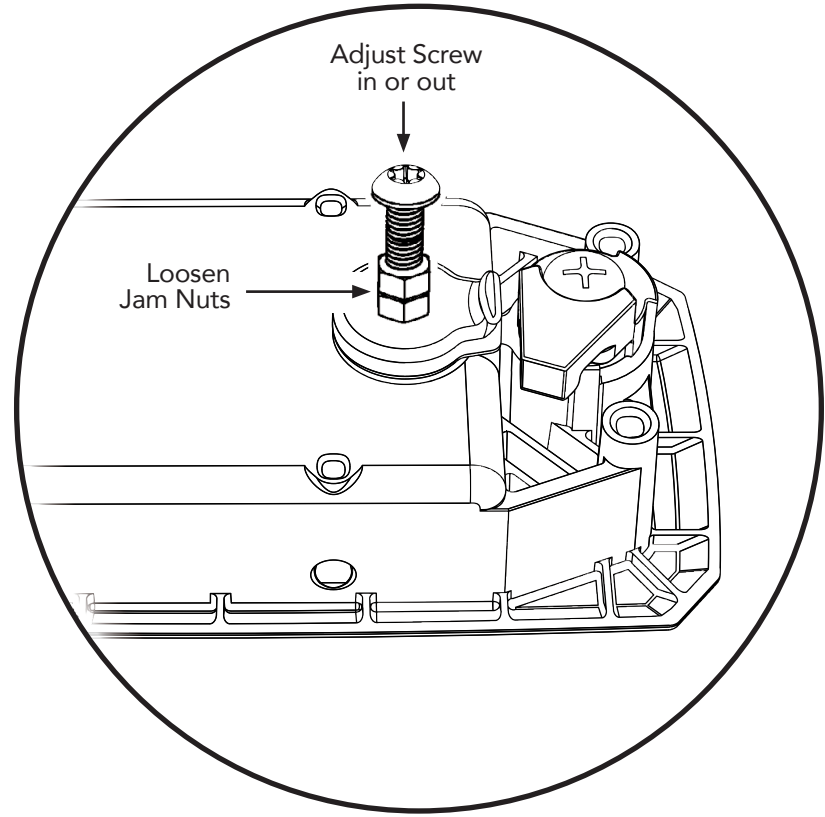

**Step 1**

Screw both Jam Nuts onto the Paddle Adjustment Screw fully, leave jam nuts loose.

Screw the Paddle Adjustment Screw with the Jam Nuts into the back side of the Paddle fully in, in the location shown. Leave loose for adjustment.

Screw the Adjustment Screw and Jam Nuts into the Paddle until the bottom Jam Nut contacts the back of the Paddle.

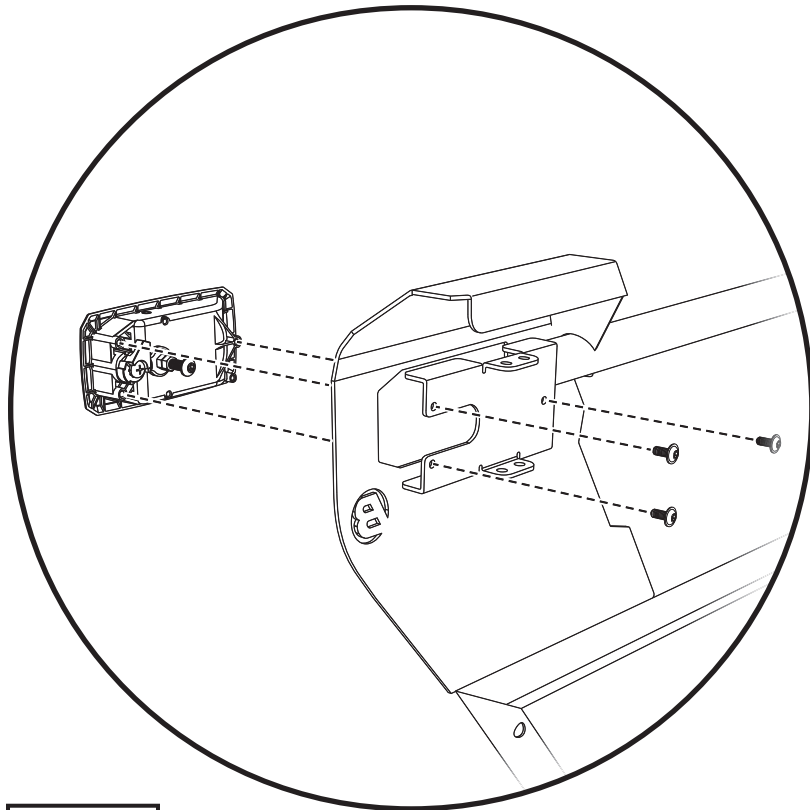
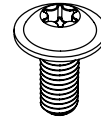
**Step 1**   531.49**Hardware**

M5x0.8x12  
Button Head Screw  
Part #531.49  
Qty. 6

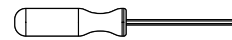
**Tools**

T20 Torx  
Driver

**Step 1**

Attach the Paddle Handle assemblies to the Element Doors.

Insert each Paddle Handle assembly into the pocket in the Element Door.

Make sure that the lock on the Paddle is toward the rear of the door.

Secure the Paddle Latches to the Element Doors using three (3) M5x0.8x12 Button Head Screws #531.49 on each latch.



<b>Step 1</b>	548.33	548.34	533.61	515.82
---------------	--------	--------	--------	--------

**Hardware**

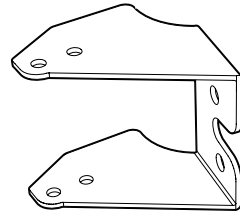
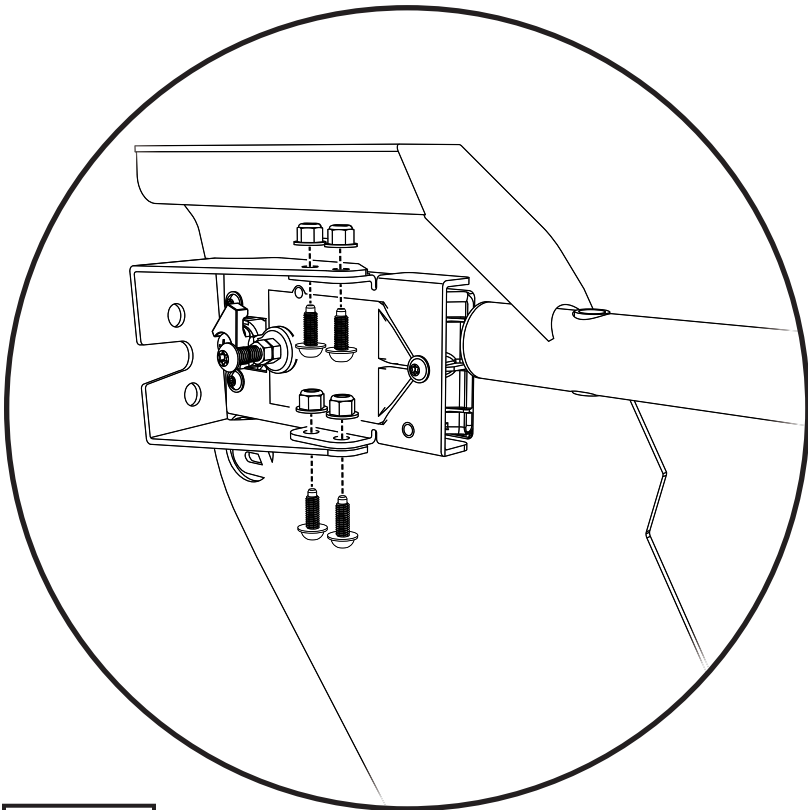

Rotor Brackets  
Part #548.33 - Left  
Part #548.34 - Right  
Qty. 1 of each

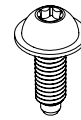

M6x1.0x15  
Flanged Button Head  
Screw  
Part #533.61  
Qty. 8



M6x1.0  
Flanged Nut  
Part #515.82  
Qty. 8

**Tools**



T30 Torx  
Driver



10mm Wrench

**Step 1**

Attach the Rotor Brackets to the rear of the Paddle Latch pockets in each door.

Attach the left Rotor Bracket #548.33 to the left side Element Door using four (4) M6x1.0x15 Flanged Button Head Screws #533.61 with M6x1.0 Flanged Nuts #515.82.

Note the position of the Rotor-mounting holes on the left Bracket shown in the illustration above.

Attach the right Rotor Bracket #548.34 to the right side Element Door using four (4) M6x1.0x15 Flanged Button Head Screws #533.61 with M6x1.0 Flanged Nuts #515.82.

**NOTE:**

Leave these fasteners loose until after you have installed the Rotor Assembly (next page).

<b>Step 1</b>	584.44	584.45	431.59	515.84
---------------	--------	--------	--------	--------

**Hardware**

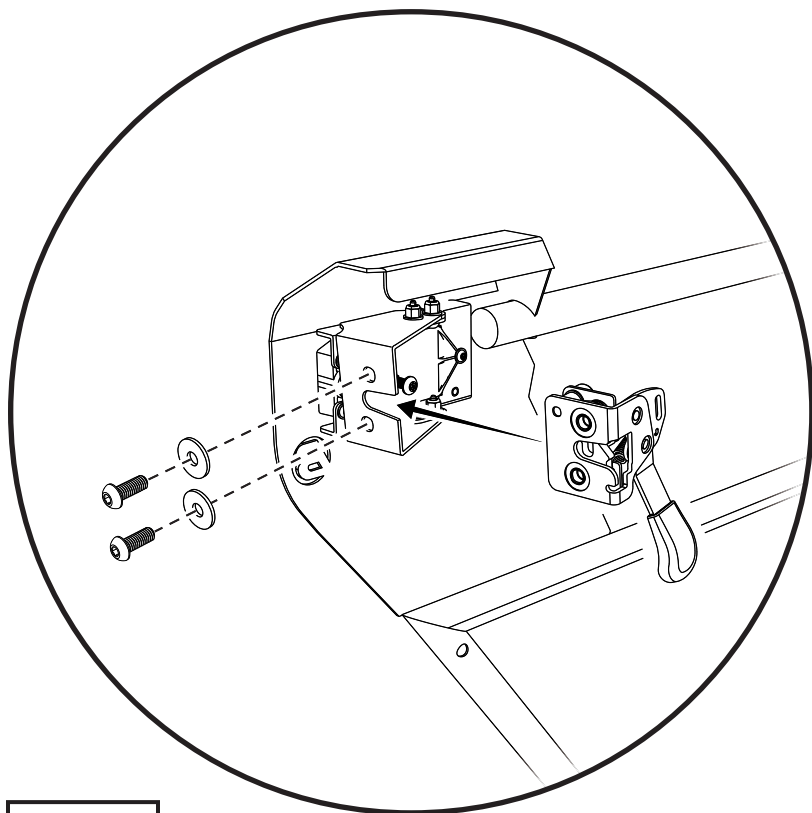

**Step 1**

Attach the Rotor Assemblies to the Rotor Brackets.

Attach the Left Rotor Assembly #584.45 to the left Rotor Bracket using two (2) M8 x 1.25 x 20 Button Head Screws #431.59 and two (2) M8 Flat Washers #515.84.

Attach the Right Rotor Assembly #584.44 to the right Rotor Bracket using two (2) M8 x 1.25 x 20 Button Head Screws #431.59 and two (2) M8 Flat Washers #515.84.

Make sure that Rotor Assembly and Paddle Assembly are aligned to each other when assembled.

Incorrectly-installed Rotor Assemblies will be crooked, and will run into the Rotor Brackets.

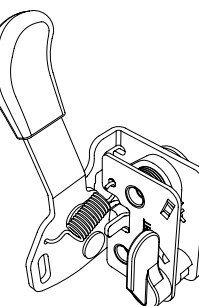

Rotor Assembly  
Part #584.45 - Left  
Part #584.44 - Right  
Qty. 1 of each

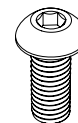

M8 x 1.25 x 20  
Button Head Screw  
Part #431.59  
Qty. 4



M8 Flat Washer  
Part #515.84  
Qty. 4

**Tools**



5mm  
Allen Wrench

**! WARNING** It is important that the Paddle Handle must align correctly with the automobile manufacturer's original equipment steel latch pin located on the vehicle. Failure to properly install the paddle handle may result in the door accidentally opening. **IMPROPER CLOSURE COULD RESULT IN SERIOUS INJURY OR DEATH TO THE OCCUPANTS. WEAR SEAT BELTS AT ALL TIMES. DRIVE CAREFULLY.**

**! CAUTION** **DO NOT** attempt to adjust the Original Equipment Latch Pin. Doing so could result in damage to the pin.

Once there is proper clearance, with no interference, tighten all fasteners. Once Rotor Assemblies attached, close the door. Make sure it locks in position, Then adjust the paddle handle adjustment screw outboard until it disengages the rotor assembly. Once it disengages, tighten the paddle handle jam nuts to lock paddle handle adjustment screw in place.

**NOTE:**

Only tighten these fasteners and the fasteners from the previous installation step after you have actuated the lock mechanism, and made sure that there is clearance between the Rotors #584.44 and #584.45, and the Rotor Brackets #584.34 and #584.33.

Step 1 585.04

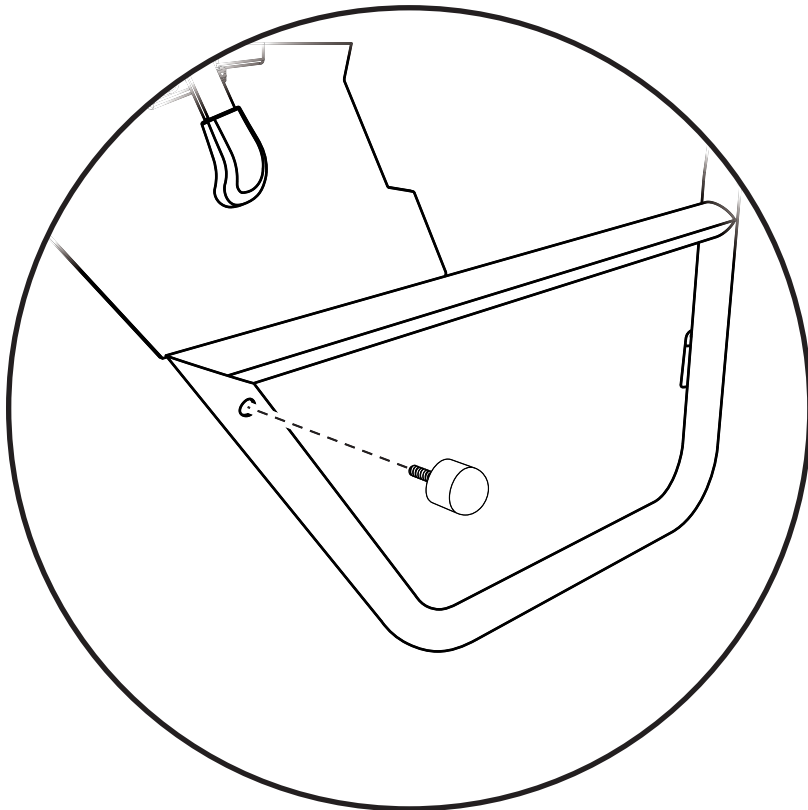

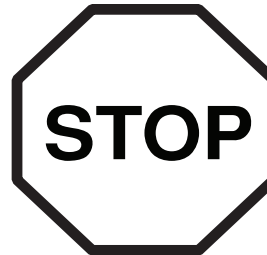

**WARNING**

The doors in this product are designed only for protection against the elements. Do not If your vehicle does not have the latch pin assembly illustrat-ed here, you have an incorrect part for your vehicle. Do not rely on the doors to contain occupants within the vehicle or to protect against injury during an accident. Door handles are only designed to aid in door closure. Door and handle will not support a person's weight.

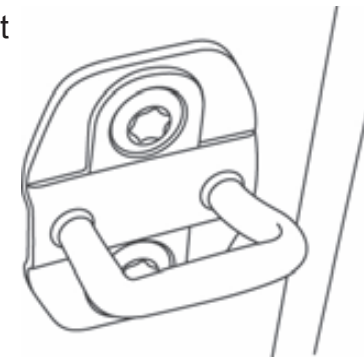

If your vehicle does not have the latch pin assembly illustrat-ed here, you have an incorrect part for your vehicle. Please

call the 1-800 number before attempting installation.



Step 1

Attach Bumpers to Element Doors.

Screw a Bumper #585.04 into the threaded hole in the lower rear inside portion of each Element Door.

Hardware

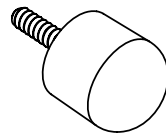

Bumper  
Part #585.04  
Qty. 2

NOTE

Special Note: The Rotary Latch Paddle Handle will only latch on the automobile manufacturer's original equipment steel latch pin located on the vehicle. Do Not adjust or remove this part.

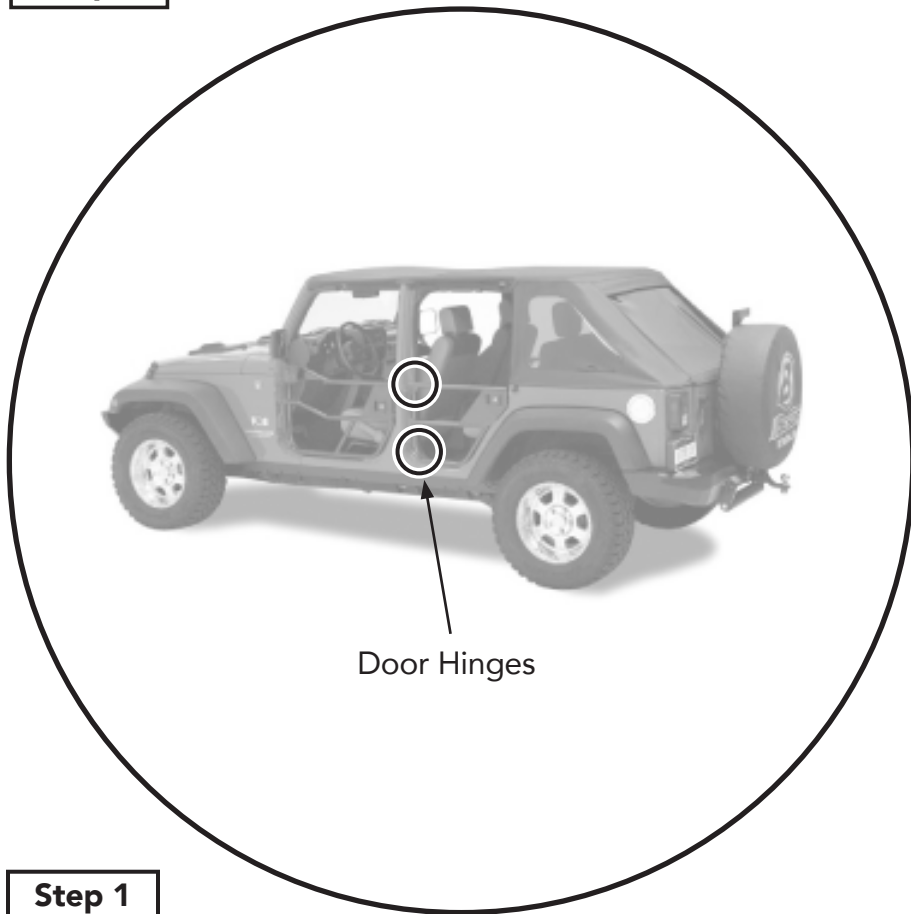
**Step 1**

Door Hinges

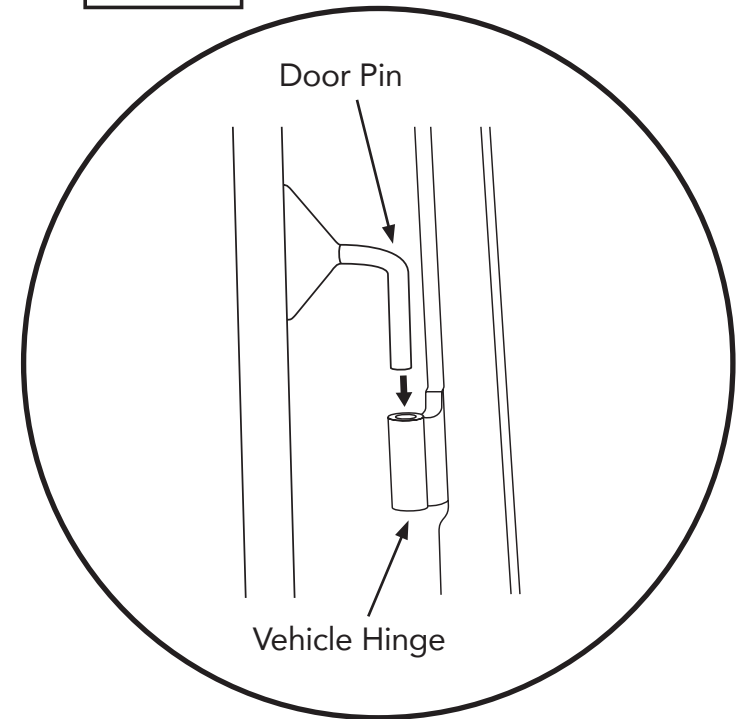
**Detail**

Door Pin

Vehicle Hinge

**Step 1**

Hold the door straight out from the vehicle with the hinge pins over the body hinges.

Lower the pins into the hinges.

Make sure that the pins are fully inserted into the body hinges.

See Detail.

**Step 1** 428.59

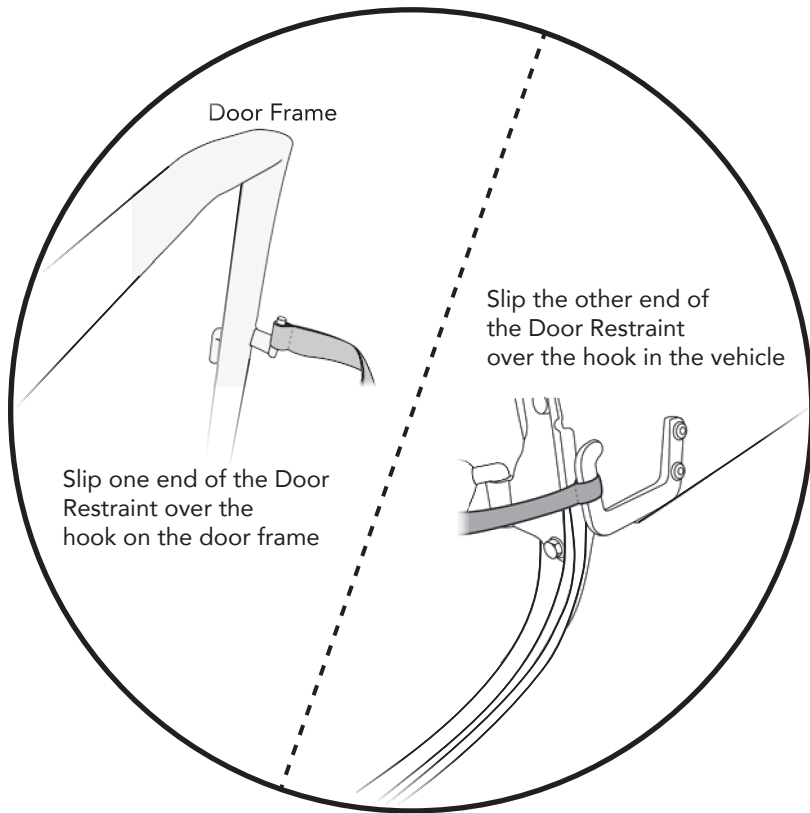

**Hardware**

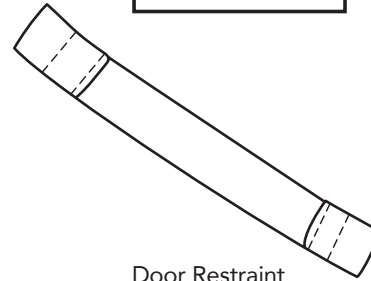

Door Restraint  
Part #428.59  
Qty. 2

**Step 1**

Locate the two (2) Door Restraints #428.59. Slip the loop in one end of a Door Restraint over the hook on the door frame.

Slip the loop in the other end of the Door Restraint over the hook on the vehicle body.

Repeat on both sides of the Jeep.

**Step 1**

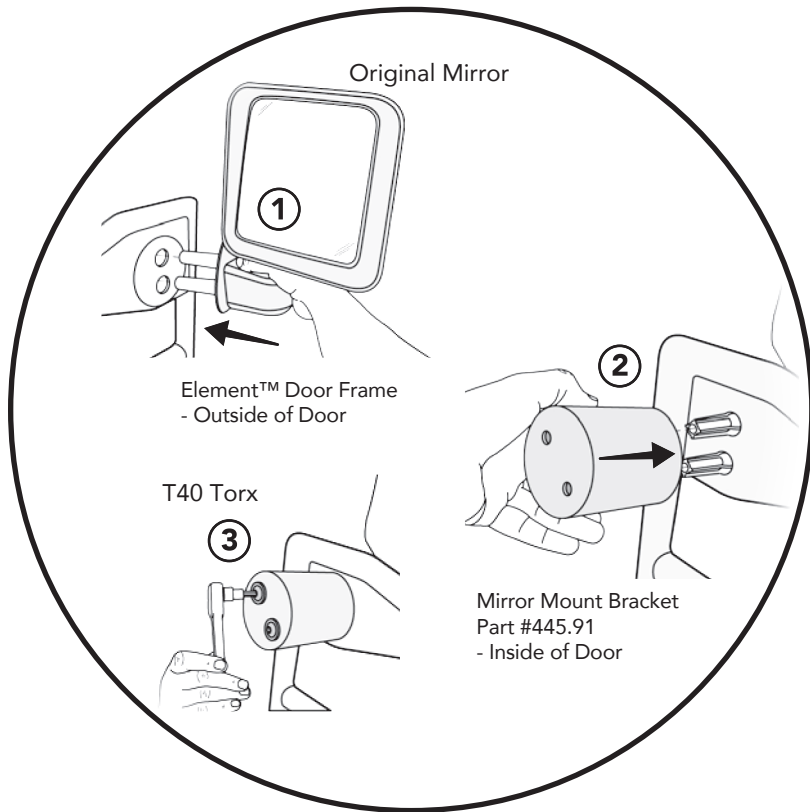

**Tools**



Ratchet



T40  
Torx Driver

**Step 2**

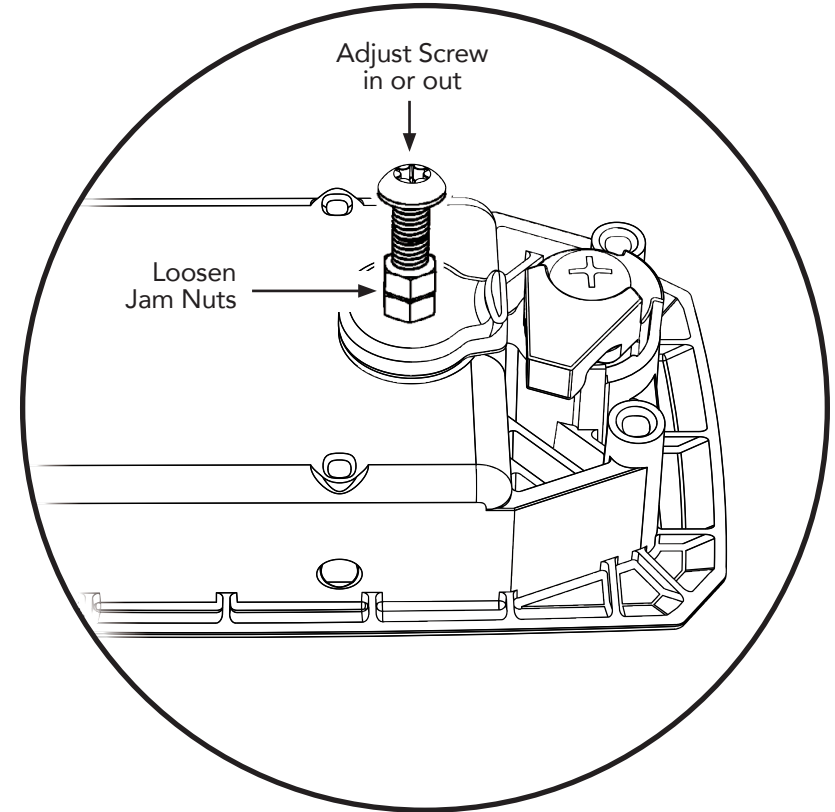

**Step 1**

The mirrors from the original doors can be mounted to the Element Doors using Mirror Mount Bracket Kit #5173401 (available separately from Bestop).

Use a T40 Torx wrench to remove the mirrors from the factory doors.

Align the holes in a Mirror Mount Bracket with the holes on the inside of the Element™ Door.

Slide the pins on the mirror through the door from the outside into the bracket. Secure using the two original mounting screws.

**Step 2**

The Paddle Latch mechanism can be adjusted using the Screw and Jam Nuts that you installed in Section 1, Page 4.

Loosen the Jam nuts to allow the Screw to be adjusted in or out, and then re-tighten the Jam Nuts to secure the Screw in place.



## Installation Instructions HighRock 4x4™ Element Rear Doors

Vehicle Application:  
Jeep® Wrangler JL 4-Door 2018 and up  
Part Number 51741-01

### WHAT BESTOP WARRANTS

Subject to the terms and conditions of sale, including any terms and conditions set forth by Bestop, Inc. ("Bestop" or "us" or "we") in our then-current terms of sale on our website (collectively, the "Terms"), Bestop represents and warrants that: the covered products listed in the "Covered Products and Warranty Periods" section (a "Product") will substantially be free from defects in materials and workmanship for the specified warranty periods set forth in that section.

### THE WARRANTY IS LIMITED AND CONDITIONAL

This warranty applies to the original purchaser of the Product only. The warranty is valid only as long as the original retail purchaser owns the vehicle upon which the Product is installed. The warranty expires should the Product be removed from the original vehicle or if the original vehicle is transferred to another owner.

This warranty is not transferable or assignable. The warranty does not apply to Product bought from auction-style or price-bid websites.

THE LIMITED WARRANTY AND STATED REMEDIES ARE SOLE AND EXCLUSIVE AND IN LIEU OF ALL OTHER WARRANTIES AND REMEDIES, AND COMPANY EXPRESSLY DISCLAIMS ALL IMPLIED OR STATUTORY OR OTHER WARRANTIES, INCLUDING WITHOUT LIMITATIONS WARRANTIES OF MERCHANTABILITY, NON-INFRINGEMENT OR FITNESS FOR A PARTICULAR PURPOSE. IN NO EVENT WILL COMPANY BE LIABLE FOR ANY SPECIAL, INCIDENTAL, CONSEQUENTIAL, PUNITIVE, INDIRECT OR EXEMPLARY DAMAGES OF ANY KIND, INCLUDING LOST PROFITS OR REVENUE, HOWEVER CAUSED, WHETHER FOR BREACH OR REPUDIATION OF CONTRACT, TORT, BREACH OF WARRANTY, NEGLIGENCE, OR OTHERWISE, WHETHER OR NOT COMPANY WAS ADVISED OF THE POSSIBILITY OF SUCH LOSS OR DAMAGES.

Some states do not allow exclusion or limitation, so this may not apply to you. This warranty gives you specific legal rights, and you may have other rights which vary from state to state.

### EXCLUSIONS TO THE WARRANTY

The Limited Warranty excludes, and Bestop is not liable in any way for any warranty claims, damages, or defects related to:

- Misuse, abuse, accidents, vandalism, negligence, fire, or improper installation or modification, or improper or inadequate maintenance;
- Failure to comply with any Product documentation, Bestop instructions, or applicable law or regulations; use in extreme conditions
- Force Majeure including but not limited to, earthquake, hurricane, tornado, flooding, or other disasters natural or man-made, civil unrest, strikes, declared or undeclared war, or lack of performance by, or discontinued product of, supply chain partners whose products, software, operations or management is beyond the control of Bestop;
- Damage resulting in breakage (including without limitation, spontaneous breakage, accidental breakage or breakage by any other means) of a Product or any component part;
- Damage to vinyl windows due to misuse, or cracking due to varying weather conditions.

### YOUR SOLE REMEDY

During the applicable warranty period, Bestop shall, at its option, either repair or replace any Product that it confirms, in its discretion, is non-compliant with the warranties herein. Bestop will not pay for labor charges associated with installation or removal of the Product. Should a specific Product be discontinued, Bestop may, at its option, replace the discontinued Product with a current product or like product.

Please retain your proof of purchase. Original proof of purchase for the Product must accompany any warranty claim. If you have a warranty claim, first you must email Bestop Customer Service at [csbestop@bestop.com](mailto:csbestop@bestop.com) for instructions. All claims must be emailed to [csbestop@bestop.com](mailto:csbestop@bestop.com) within 30 days of discovery of a defective Product, but in no event later than thirty days after the end of the applicable Warranty Period (the "Warranty Notice Period"). Warranty claims made after the Warranty Notice Period are null and void and Bestop shall have no responsibility with respect to such claims.

THIS SECTION SETS FORTH BESTOP'S SOLE OBLIGATION & YOUR SOLE REMEDY WITH RESPECT TO ANY DEFECTS OR OTHER PRODUCT ISSUE. ANY PRODUCTS REPLACED UNDER TERMS OF THIS WARRANTY WILL BE COVERED UNDER TERMS & BALANCE OF THE DURATION OF THE ORIGINAL LIMITED WARRANTY FOR SUCH PRODUCT.



## Installation Instructions HighRock 4x4™ Element Rear Doors

Vehicle Application:  
Jeep® Wrangler JL 4-Door 2018 and up  
Part Number 51741-01

**COVERED PRODUCTS AND WARRANTY PERIODS:** The warranty time periods are as follows for Products manufactured by Bestop:

### **BESTOP® LIMITED LIFETIME WARRANTY**

Trektop® Pro Twill Fabric Top Sunrider® for Hardtop Twill Fabric Top  
Trektop® NX Glide Twill Fabric Top Replace-a-Top™ Twill Fabric Top  
Trektop® NX Twill Fabric Top Supertop® NX Twill Fabric Top  
EZFold™ Soft Tonneaus Floor & Cargo Liners  
ZipRail™ Soft Tonneaus Pet Barriers  
EZRoll™ Soft Tonneaus

### **BESTOP® 5-YEAR LIMITED WARRANTY**

Trektop® NX Glide™ Top (non-Twill) Sunrider® for Hardtop (non-Twill) Replace-a-Top™ Top (non-Twill) Trektop® NX Top (non-Twill)  
Sailcloth Replace-a-Top™ Supertop® NX Top (non-Twill)  
Tigertop™ and Halftop™ Supertop® Classic Soft Top Sunrider® Complete Soft Top Supertop® for Truck  
EZ Fold Hard Tonneau

### **BESTOP® 3-YEAR/100K MILES LIMITED WARRANTY**

Powerboard® & Powerboard® NX

Trekstep®, Side Mount  
Trekstep®, Rear Mount

### **BESTOP® 3-YEAR LIMITED WARRANTY**

Pavement Ends Sprint Top

### **BESTOP® 2-YEAR LIMITED WARRANTY**

Trektop® Classic Soft Top  
RoughRider™ Soft Storage

### **BESTOP® 1-YEAR LIMITED WARRANTY**

All other Bestop® & Pavement Ends™ products not specified above.

**For further information or request for warranty work, please contact:**

**Bestop Inc. Customer Service**  
**Toll-Free: (800)845-3567**  
**Main: (303)465-1755**  
**E-mail: [csbestop@Bestop.com](mailto:csbestop@Bestop.com)**  
**Website: [www.Bestop.com](http://www.Bestop.com)**